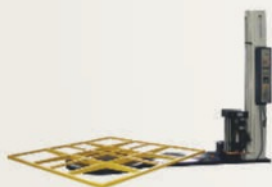

Model: CLASSIC

**Pallet Stretch Wrapper -
with Top platen**

**Pallet Stretch Wrapper -
4 meter height Mast**

**Pallet Stretch Wrapper -
4 meter Turntable dia.**

**Pallet Stretch Wrapper -
3.2 meter Turn table**

Salient Features:

- Fully automatic operation machine
- Heavy duty turn table for all industrial applications
- Powered pre-stretch unit ensures stronger packing, while consuming least quantity of film
- Modular in construction
- Powered pre-stretch upto 300% stretch
- Flexible ramp location

Applications: Textile yarns like cotton, polyester, jute etc., castings, canned foods, bottle crates, fertilizers or grains in sacks & bags, pails & tins, carton boxes, ceramic items, tiles and many more ...

Specifications

CAPACITY: Production speed : 15 - 25 Pallets / hour Pallet size : 1200 x 1200 mm Pallet height : 2600 mm Max. weight / pallet : 2000 kg	MACHINE: * Turn table diameter : 1500 mm Turn table height : 80 mm Turn table speed : 1-10 rpm Max. powered stretch : 300% Installed power : 1.5 kW Power supply : 220V, Single phase, 50 Hz	FILM DETAILS: Material : LLDPE Stretch film Film width : 250 - 500 mm Film thickness-Range : 12 - 35 μ Film thickness-Used : 23 μ Core diameter : 76 mm Max. Film diameter : 250 mm
--	---	--

* We also offer custom built machines to suit your product requirements

Layout - Classic

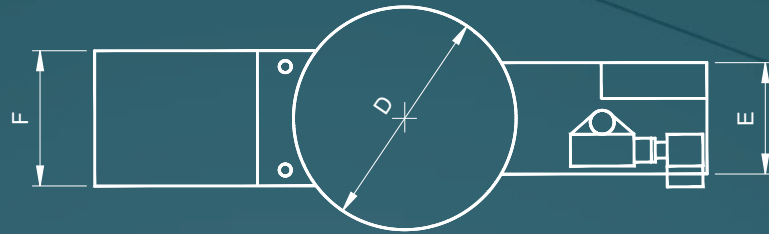

Turn Table Diameter				
Details	1500mm Ø	1800mm Ø	2000mm Ø	2500mm Ø
A	1440	1440	1440	1440
B	2700	3020	3275	3700
C	2740	2740	2740	2740
D	1500	1800	2000	2500
E	765	765	765	865
F	1000	1000	1000	1000

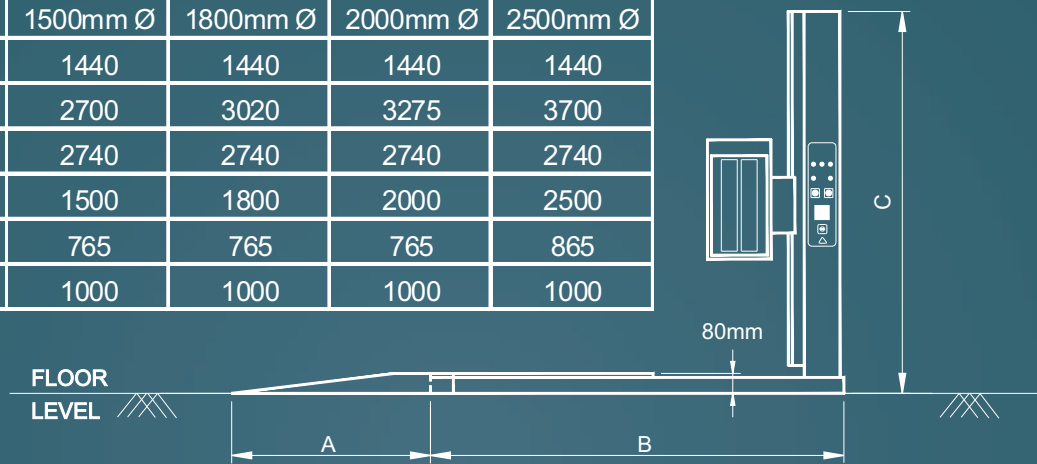

Note: All dimensions are in mm

Manufactured by



Factory:

3 / 184, Kondayampalayam
 Vaiyampalayam Post
 Coimbatore - 641 110. Tamil Nadu INDIA
 Tel: +91 94436 77432 , +91 94436 77804

Office:

"The Rookery", 46-B, KRK Road
 Krishnasamy Nagar II Layout
 Ramanathapuram
 Coimbatore - 641 045. Tamil Nadu INDIA
 Tel: +91 - 422 - 231 56 40 / 41 /44



✉ info@penguin.in

🌐 www.penguin.in